

Moulinex®

EASY FRY 5L

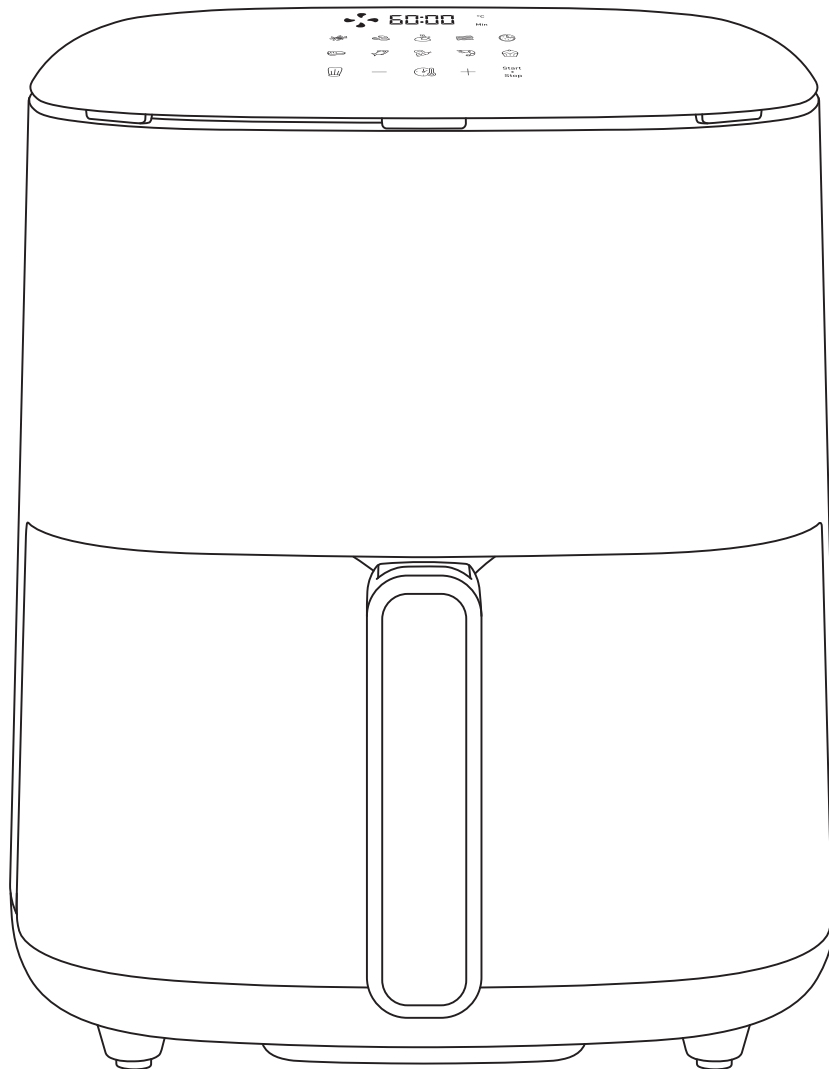

en

fr

de

nl

es

pt

it

el

en manual online
fr notice en ligne
de anleitung online
nl handleiding online
es manual en línea
pt manual online
it manuale online
el εγχειρίδιο online



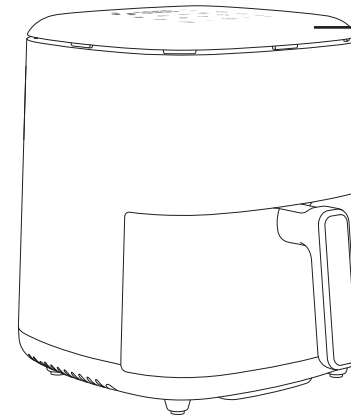

DIGITAL TOUCHSCREEN PANEL

fr Ecran digital tactile - **de** Digitaler Touchscreen Bildschirm - **nl** Digitaal touchscherm - **es** Pantalla táctil digital - **pt** Ecrã tátil digital - **it** Touchscreen digitale - **el** Ψηφιακή οθόνη αφής

DRAWER

fr Cuve - **de** Garkorb - **nl** Lade - **es** Cubeta - **pt** Cuba - **it** Teglia - **el** Τάψι

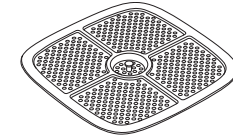

REMOVABLE GRID

fr Grille standard amovible - **de** Herausnehmbarer Gittereinsatz - **nl** Uitneembare standaard plaat - **es** Parrilla estándar extraíble - **pt** grelha padrão amovível - **it** griglia removibile standard - **el** αφαιρούμενη σχάρα κανονικού μεγέθους

COOKING TIPS

fr CONSEILS DE CUISINE - **de** KOCHTIPPS - **nl** KOOKTIPS - **es** CONSEJOS DE COCINA - **pt** GRELHA PADRÃO AMOVÍVEL - **it** GRIGLIA REMOVIBILE STANDARD - **el** ΑΦΑΙΡΟΥΜΕΝΗ ΣΧΑΡΑ ΚΑΝΟΝΙΚΟΥ ΜΕΓΕΘΟΥΣ



MAKE SURE YOU ALWAYS PLACE ENOUGH FOOD ON THE BAKING PAPER TO KEEP IT AT THE BOTTOM OF THE DRAWER.

fr Assurez-vous de toujours placer suffisamment de nourriture sur le papier cuisson pour le maintenir au fond du tiroir. - **de** Achten Sie darauf, immer genug Lebensmittel auf das Backpapier zu legen, damit es am Boden der Schublade bleibt. - **nl** Zorg ervoor dat je altijd genoeg voedsel op het bakpapier legt om het op de bodem van de lade te houden. - **es** Asegúrate de colocar siempre suficiente comida sobre el papel de hornear para que se mantenga en el fondo del cajón. - **pt** Certifique-se de colocar sempre comida suficiente sobre o papel vegetal para que ele se mantenha no fundo da gaveta. - **it** Assicurati di mettere sempre abbastanza cibo sulla carta da forno affinché rimanga sul fondo del cassetto. - **el** Βεβαιώσου ότι τοποθετείς πάντα αρκετό φαγητό πάνω στο χαρτί ψησίματος ώστε να παραμένει στον πάτο του συρταριού.



SHAKE REGULARLY YOUR FOODS IN THE DRAWER FOR HOMOGENEOUS COOKING

fr Mélangez régulièrement vos aliments pour une cuisson homogène. - **de** Schütteln Sie Ihre Lebensmittel in der Schublade regelmäßig für homogenes Garen. - **nl** Schud regelmatig uw voedsel in de lade voor homogeen koken. - **es** Agita regularmente tus alimentos en el cajón, para una cocción homogénea. - **pt** Mexa regularmente para garantir que os alimentos são cozinhados de forma uniforme. - **it** Girare di tanto in tanto per fare in modo che gli alimenti siano cotti in maniera omogenea. - **el** Ανακατεύετε τακτικά για να διασφαλίσετε ότι το φαγητό μαγειρεύεται ομοιόμορφα.



OVEN-PROOF DISHES COMPATIBLE

fr Plats à four compatibles - **de** Backofengeeignetes Geschirr kompatibel - **nl** Geschikt voor ovengerechten - **es** Compatible con platos aptos para horno - **pt** Compatível com travessas para forno - **it** Piatti compatibili per la cottura al forno - **el** Πιάτα συμβατά με φούρνο

TEMPERATURE DISPLAY

fr Affichage de la température - de Temperaturanzeige
 - nl Temperatuurscherm - es Pantalla de la Temperatura - pt Ecrã da temperatura - it Indicazione temperatura - el Ένδειξη θερμοκρασίας

TIMER DISPLAY

fr Affichage du minuteur - de Timer-Anzeige - nl Timerscherm
 - es Pantalla del Temporizador - pt Ecrã do temporizador
 - it Indicazione timer - el Ένδειξη χρονοδιακόπτη



10 PRE-SETS PROGRAMS

fr 10 programmes prédéfinis
 - de 10 voreingestellte Programme
 - nl 10 automatische programma's
 - es 10 programas preestablecidos
 - pt 10 programas predefinidos
 - it 10 programmi preimpostati
 - el 10 προεπιλεγμένα προγράμματα

SELECTION TOUCH FOR PRESET PROGRAMS

fr Touche de sélection des programmes prédéfinis - de Auswahl Schaltfläche für voreingestellte programme - nl Selectietoets voor automatische programma's - es Selección táctil de los programas preestablecidos - pt Toque de seleção para programas predefinidos - it Display touch screen per i programmi preimpostati - el Επιλογή αφής για προεπιλεγμένα προγράμματα

TEMPERATURE SETTING











fr Réglage de la température - de Temperatureinstellung - nl Temperatuurinstelling - es Ajuste de Temperatura - pt Definição da temperatura - it Impostazione temperatura - el Ρύθμιση της θερμοκρασίας

COOKING TIME SETTING

fr Réglage du temps de cuisson - de Garzeiteinstellung - nl Instelling Bereidingstijd - es Ajuste de tiempo de Cocinado - pt Definição do tempo de cozedura - it Impostazione del tempo di cottura - el Ρύθμιση χρόνου μαγειρέματος





















PROGRAMS

fr PROGRAMMES - de PROGRAMME - nl PROGRAMMA - es PROGRAMAS - pt PROGRAMAS - it PROGRAMMI - el ΠΡΟΓΡΑΜΜΑΤΑ

 <p>FRENCH FRIES fr Frites - de Pommes frites - nl Friet - es Papas a la francesa - pt Fritas - it Patatine fritte - el Τηγανιτές πατάτες</p>	 <p>NUGGETS fr Nuggets / croquettes - de Nuggets - nl Nugggets - es Pepitas - pt Nuggets frango - it Crocchette di pollo - el κοτομπουκιές</p>	 <p>ROASTED CHICKEN fr Poulet rôti - de Hähnchen - nl Gebraden kip - es Pollo asado - pt Frango assado - it Pollo arrosto - el Ψητό κοτόπουλο</p>	 <p>BACON / BEEF BACON fr Bacon - de Speck - nl Spek - es Tocino - pt Bacon - it Pancetta - el Μπέικον</p>	 <p>PIZZA fr Pizza - de Pizza - nl Pizza - es Pizza - pt Pizza - it Pizza - el Πιτσο</p>
 <p>STEAK fr Steak - de Steak - nl Biefstuk - es Carne - pt Bife - it Carne - el μπριζόλα</p>	 <p>FISH fr Poisson - de Fisch - nl Groenten - es Pescado - pt Peixe - it Pesce - el Ψάρι</p>	 <p>VEGETABLES fr Légumes - de Gemüse - nl Vis - es Verduras - pt Legumes - it Verdure - el Λαχανικά</p>	 <p>SHRIMPS fr Crevettes - de Garnelen - nl Garnalen - es Camarón - pt Camarão - it Gamberetti - el Γαρίδες</p>	 <p>DESSERTS fr Desserts - de Dessert - nl Nagerecht - es Postres - pt Sobremesa - it Dolce - el Επιδόρπιο</p>

COOKING GUIDE

fr GUIDE DE CUISSON - de ANLEITUNG ZUM KOCHEN - nl KOOKGIDS - es GUÍA DE COCINA - pt GUIA DE COZEDURA - it GUIDA ALLA COTTURA - el ΟΔΗΓΟΣ ΜΑΓΕΙΡΙΚΗΣ

Icon	Weight	Time	Temp	Icon	Shake
POTATOES & FRIES - POMMES DE TERRE & FRITES - KARTOFFELN & POMMES - AARDAPPELEN & FRIET - PAPAS Y PAPAS FRITAS - ΒΑΤΑΤΑΣ Ε ΒΑΤΑΤΑΣ FRITAS - ΡΑΤΑΤΕ Ε ΡΑΤΑΤΙΝΕ FRITTE - ΠΑΤΑΤΑΤΕΣ ΚΑΙ ΠΑΤΑΤΑΚΙΑ					
	300 - 800 g	20 - 30 min	180 °C		Yes
MEAT & POULTRY - VIANDE & VOLAILLE - GEFLÜGEL & FLEISCH - VLEES & GEVOGELTE - CARNE & AVES DE CORRAL - CARNE E AVES - CARNE E POLLAME - ΚΡΕΑΣ ΚΑΙ ΠΟΥΛΕΡΙΚΑ					
	100 - 500 g	6 - 10 min	180°C		
	100 - 500 g	12 - 19 min	180°C		
	1000 g	45 min	200°C		
FISH - POISSON - FISCH - VIS - PEZ - PEIXE - PESCE - ΨΑΡΙ					
	350 g	15 - 17 min	140°C		
	12 pcs	4 min	170°C		Yes
SNACKS - HAPJES - APERITIVOS - LANCHES - SNACK - ΣΝΑΚ					
	100 - 600 g	7 - 15 min	200°C		Yes
	400 g	7 min	190°C		
VEGETABLES - LÉGUMES - GEMÜSE - GROENTEN - VERDURAS - VEGETAIS - VERDURE - ΛΑΧΑΝΙΚΑ					
	400 - 700 g	15 min	180°C		
BAKING - PÂTISSERIE - BACKEN - BAKKEN - HORNADA - SOBREMESAS - DOLCI - ΕΠΙΔΟΡΠΙΑ					
	7 pcs	15 - 18 min	180°C		

CLEANING TIPS

fr CONSEILS DE NETTOYAGE - de TIPPES ZUR REINIGUNG - nl SCHOONMAAK-TIPS - es CONSEJOS DE LIMPIEZA - pt SUGESTÕES DE LIMPEZA - it SUGGERIMENTI PER LA PULIZIA - el ΣΥΜΒΟΥΛΕΣ ΚΑΘΑΡΙΣΜΟΥ

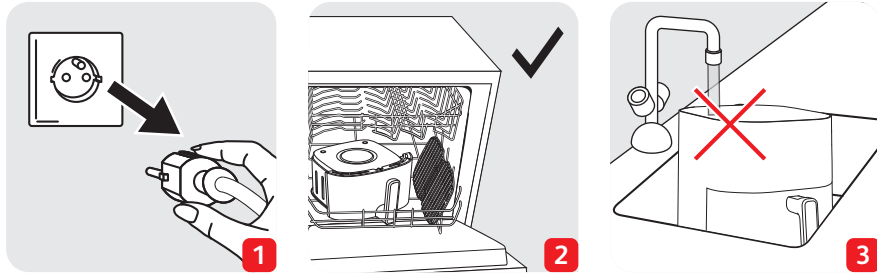

SAFETIES

fr SÉCURITÉ - de SICHERHEITEN - nl VEILIGHEDEN - es SEGURIDADES - pt SEGURANÇAS - it SICUREZZE - el ΑΣΦΑΛΕΙΑΣ

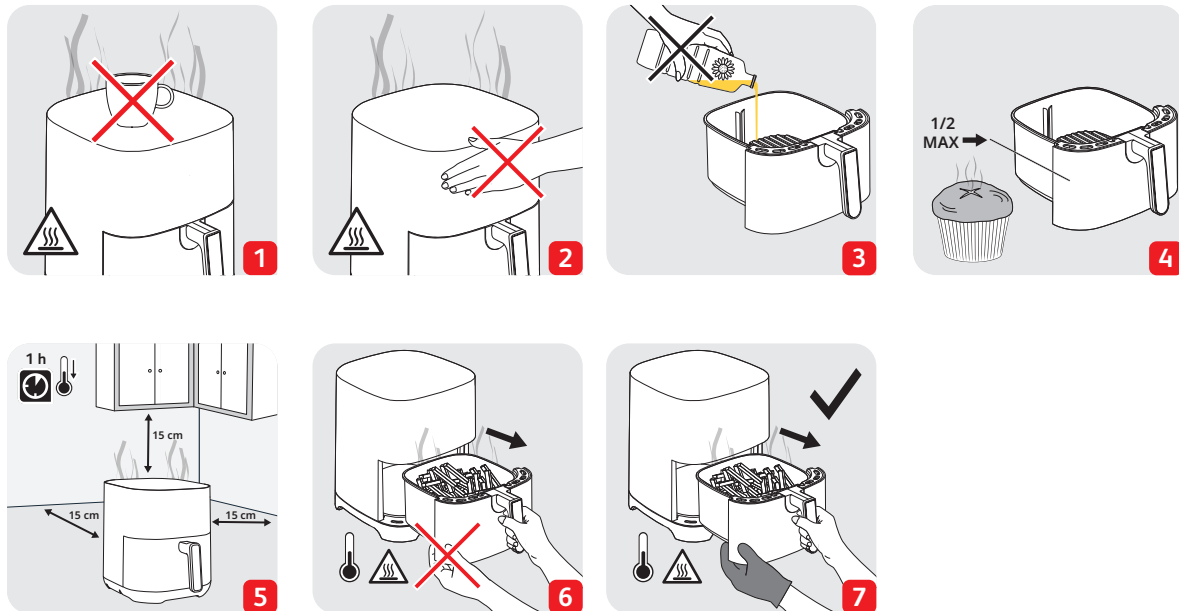

EASY FRY 5L



DOWNLOAD MOULINEX RECIPE APP

fr TÉLÉCHARGEZ L'APP DE RECETTES MOULINEX
de DOWNLOAD DER MOULINEX REZEPTE-APP
nl MOULINEX RECEPTEN-APP DOWNLOADEN
es DESCARGA LA APP MOULINEX
pt TRANSFERIR A APP DE RECEITAS DA MOULINEX
it SCARICA L'APP DELLE RICETTE MOULINEX
el ΚΑΝΤΕ ΛΗΨΗ ΤΗΣ ΕΦΑΡΜΟΓΗΣ ΣΥΝΤΑΓΩΝ ΤΗΣ MOULINEX



JOIN THE MOULINEX MOVEMENT !

fr REJOIGNEZ LE MOUVEMENT MOULINEX ! - de WERDEN SIE TEIL DER MOULINEX COMMUNITY!
nl DOE MEE MET DE MOULINEX-BEWEGING! - es ÚNETE A LA APP MOULINEX - pt JUNTE-SE AO MOVIMENTO MOULINEX!
- it UNISCITI A MOULINEX! - el ΕΛΑΤΕ ΚΑΙ ΕΞΕΙΣ ΣΤΟ ΚΙΝΗΜΑ ΤΗΣ MOULINEX!



MOULINEX APP



YOUTUBE CHANNEL

fr CHAÎNE YOUTUBE - de YOUTUBE KANAL -
nl YOUTUBE KANAAL - es CANAL DE YOUTUBE -
pt CANAL DO YOUTUBE - it CANALE YOUTUBE - el ΚΑΝΑΛΙ YOUTUBE



MOULINEX ON INSTAGRAM

POST YOUR RECIPES #EASYFRYFAMILY

fr POSTEZ VOS RECETTES #EASYFRYFAMILY - de VERÖFFENTLICHEN SIE IHRE REZEPTE #EASYFRYFAMILY - nl POST JE RECEPTEN #EASYFRYFAMILY - es PUBLIQUE SUS RECETAS #EASYFRYFAMILY - pt PUBLIQUE AS SUAS RECEITAS #EASYFRYFAMILY - it PUBBLICA LE TUE RICETTE #EASYFRYFAMILY - el ΔΗΜΟΣΙΕΥΣΤΕ ΤΙΣ ΣΥΝΤΑΓΕΣ ΣΑΣ #EASYFRYFAMILY

